

Syncro Si Status Unit and Hold Off

Product Manual

Man-1099 Issue 03 October 2009

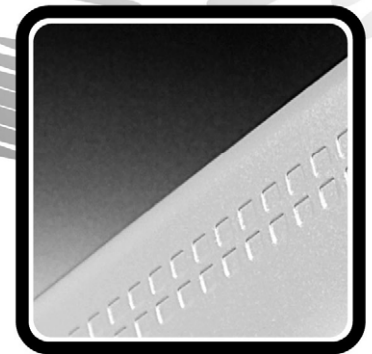

1. Introduction

Syncro Si Status units and Hold off units allow control and indication of the essential functions of the Syncro XT gas extinguishing system by connecting to any point on the Apollo protocol analogue addressable fire detection and alarm loop wiring.

Status units are available with indicators only, with a manual release control or with a manual release and mode select controls.

Hold off units are available in surface mounting enclosures.

The ability to connect to any point on the analogue addressable fire detection and alarm loop wiring offers convenience and cost saving as additional wiring does not need to be fitted from these points back to the control panel.

Status units and Hold off units can simply be fitted and added to the system via the Loop Explorer configuration programme.

They will automatically carry out the required actions without any additional configuration being required.

2. Safety

Suppliers of articles for use at work are required under section 6 of the Health and Safety at Work act 1974 to ensure as reasonably as is practical that the article will be safe and without risk to health when properly used.

An article is not regarded as properly used if it is used 'without regard to any relevant information or advice' relating to its use made available by the supplier.

This product should be installed, commissioned and maintained by trained service personnel in accordance with the following:

- (i) IEE regulations for electrical equipment in buildings
- (ii) Codes of practice
- (iii) Statutory requirements
- (iv) Any instructions specifically advised by the manufacturer

According to the provisions of the Act you are therefore requested to take such steps as are necessary to ensure that you make any appropriate information about this product available to anyone concerned with its use

3. Installation

Installation of the units should be carried out by qualified personnel only. The electronic components within the units are vulnerable to physical damage and damage by electrostatic discharges.

It is advisable to wear a wrist strap designed to prevent the build-up of static charges within the body, before handling any electronic circuit boards.

Never insert or remove boards or components with the power on.

Mounting the boxes

The site chosen for the location of the units should be clean and dry and not subject to shock or vibration. The temperature should be in the range -5° to +35° C, the humidity should not exceed 95%.

Remove the front plate by taking out the two fixing screws and put them in a safe place for re-fitting later.

Remove knockouts from the top and or back of the box in the positions at which cables will enter.

Using the box as a template, mark the position of the fixing holes, ensuring that the wall is flat at the chosen location. Screws or bolts of a minimum of 5mm diameter and 40mm long must be used to mount the enclosure in all mounting positions.

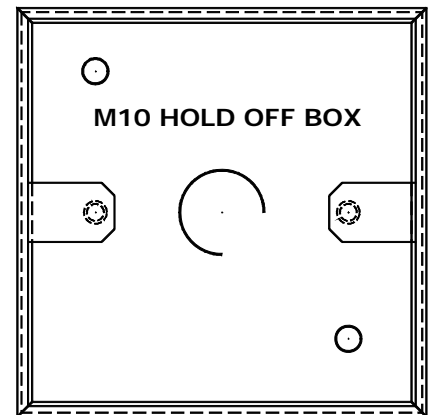
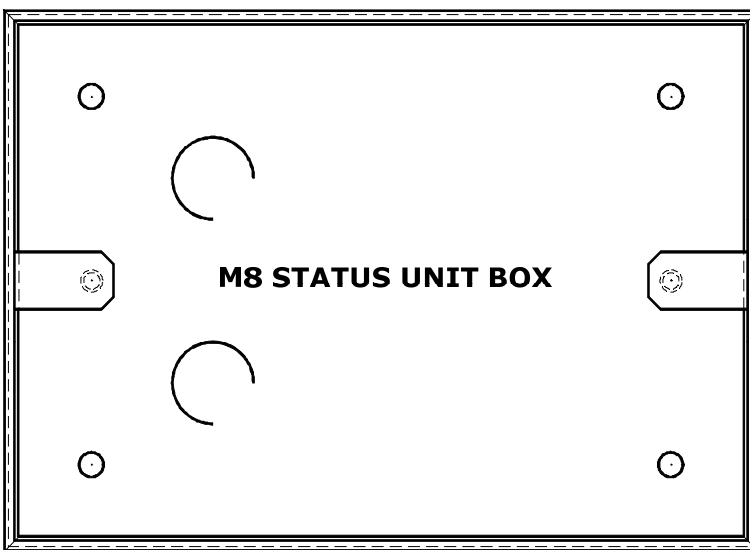

After the box is firmly fixed, remove any knockout blanks and dust or swarf caused by drilling and fixing the box.

4. Cabling

Cables should be brought into the cabinet using the knockouts provided and where necessary, using couplers to maximise the space within the enclosure. Use the knockouts closest to the terminating position for each cable, to ensure cable length within the enclosure is kept to a minimum.

Ensure that only the numbers of knockouts are removed to meet the cable termination requirements, as any additional apertures in the enclosure will compromise the IP30 ingress protection.

Brass inlet bushings or cable glands should be used to maintain insulation and to ensure EMC compliance.

The screen or drain wires should be bonded to earth via metal cable glands.

The maximum size of cable, which can be terminated, is 2.5² mm.

The communications protocols are highly immune to noise but sensible segregation from known noise generating sources such as mains cables is recommended.

4.1 Cable Termination

Drain wires need to be terminated at the brass cable gland to ensure EMC compliance.

To ensure good earth bonding at entry to the panel enclosure, it is recommended that the cable drain wires are terminated using Pirelli AXT brass cable glands. These glands have a slotted fixing thread, which allows the drain wire to be clamped between the gland fixing nut and panel enclosure. To ensure that a good earth bonding between the drain wire and panel case, a 20mm shakeproof washer should be used, as shown in the termination diagram below.

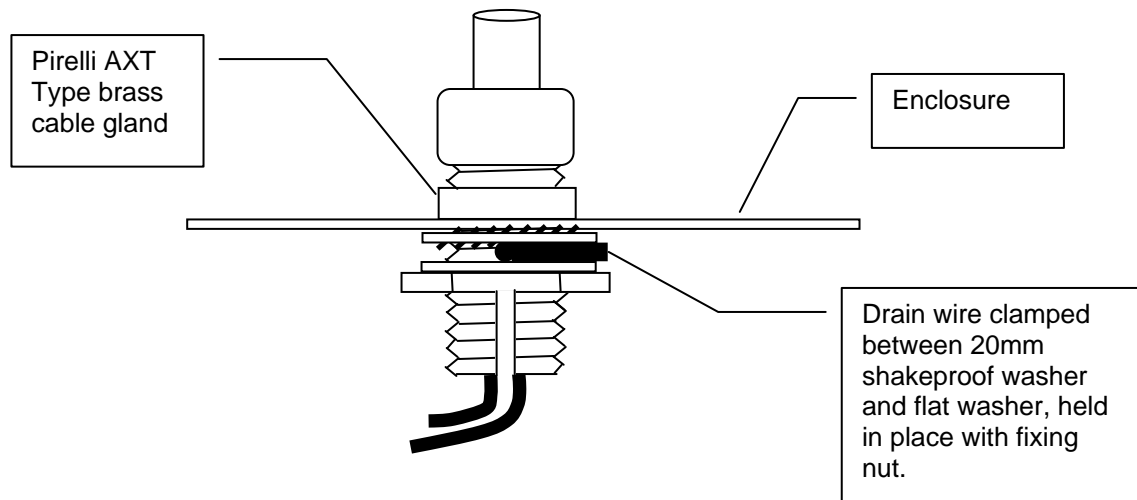

5. Connecting to the units

All connections to the unit are via 5mm pitch, 2.5mm² capacity, spring leaf terminal blocks. Care should be taken to use the correct sized terminal screwdriver and not to over tighten the terminals.

If stranded cables are used then care should be taken to ensure that all strands are contained in the terminal and that there are not any loose strands which may cause short circuits to other terminals or cables.

Status Unit

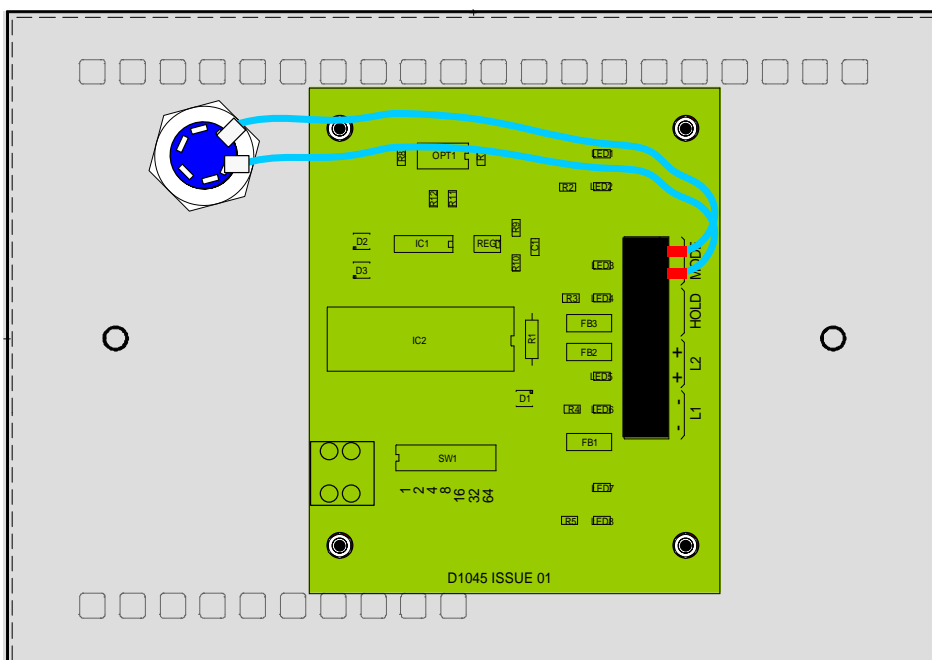

Hold Off Unit

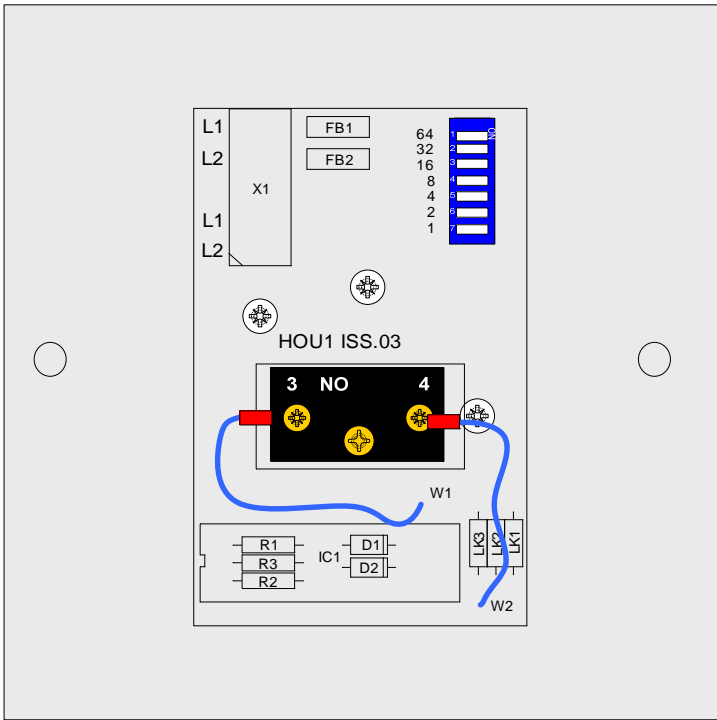

6. Address switch

All types of unit have a 7 way DIL switch to set the address. The settings for this switch are different to devices made by Apollo and setting should be as per the examples below.

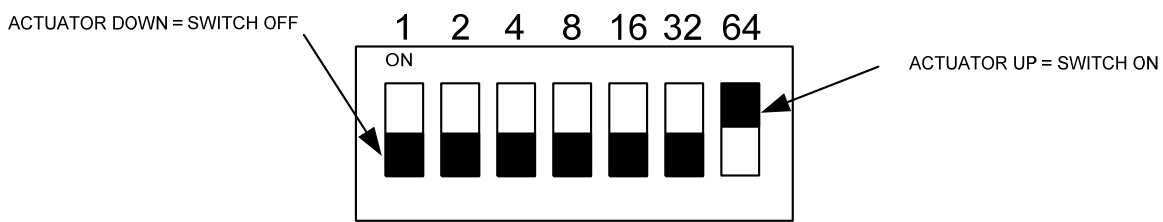

This switch setting shows address 64.

To add a Status or Hold unit to a Loop Explorer configuration, highlight the required loop in the left hand pane and select the **Status** tab. Double click the Status unit icon and a Status unit will appear at the next available address on the loop. The Status unit icon is also used for the Hold Off unit, as this has the same device type code.

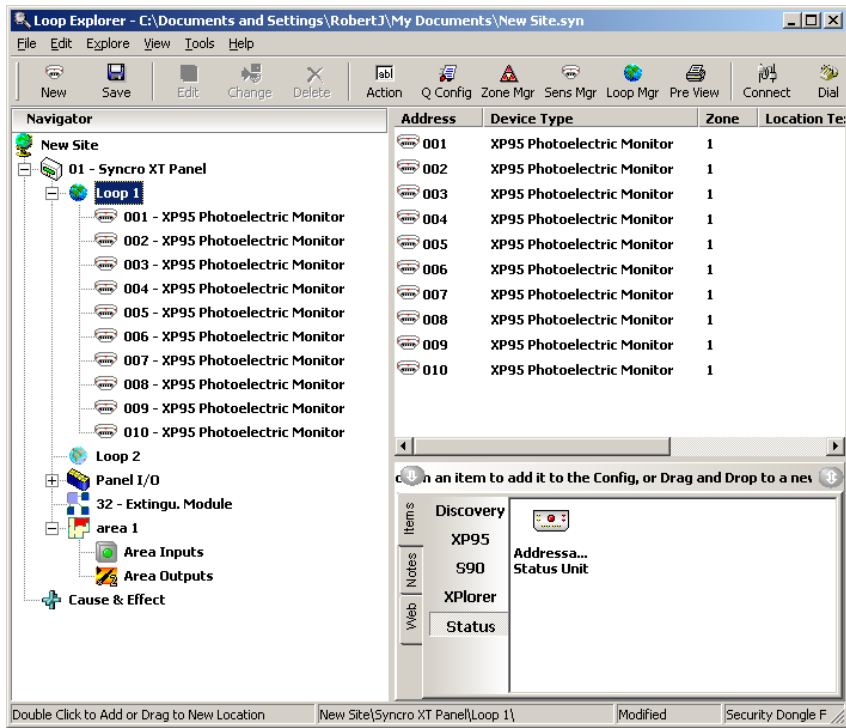

To change the address of the Status or Hold off unit, right click its icon and select device operations then change address from the drop down menus.